

ONLINE SOFTWARE TRAINING REPORT

ON

“AutoCAD”

AT

LEARN DELTA

Submitted in partial fulfilment of the
requirements for the award of degree of
Bachelor of Technology

In

Civil Engineering



Submitted To :
Sindhusha NG
(Asst. Professor)
in Civil
Engineering
GIET(A)

Submitted By :
Balajit Rai
(20551A0186)



DEPARTMENT OF CIVIL ENGINEERING
GODAVARI INSTITUTE OF ENGINEERING &
TECHNOLOGY (AUTONOMOUS)

CHAITANYAKNOWLEDGE CITY, NH - 16, RAJAMAHENDRAVARAM(A.P)

Jawaharlal Nehru technological University, Kakinada, A.P,
India JULY 2022

ACKNOWLEDGEMENT

I am highly grateful to, **Dr. VENKATESWARULU HOD (Civil Department)** for providing this opportunity to carry out one-month practical training at **LEARNDELTA**.

The constant guidance and encouragement received from **SINDHUSA Asst. Professor (civil engg.)** has been of great help in carrying out the project work and is acknowledged with reverential thanks.

I would like to express gratitude to other faculty members of **civil engineering** department for their intellectual support throughout the course of this work.

Finally, I am indebted to all whosoever have contributed in this report

Abstract

Software training is one of the requirements to be fulfilled in order to obtain the Bachelor's Degree in Technology. Each student needs to do software training in a recognized company of their respective domain. The students are compulsory to the training for duration 1 month which is intended for their exposure to the software industry. A well planned, properly executed and evaluated software training helps a lot in developing a professional attitude. It develops an awareness of software approach to problem solving, based on a broad understanding of processes. Besides software training build self confidence among students and let students know the technical knowledge and professionalism.

During software training at "Interenshala", most of the theoretical knowledge gained during the course of studies was put to test. Various efforts and processes involved in designing of a component was studied and understood during the training. In our training I undertook course of AutoCAD.

The training gave me good experience from the view of implementing my theoretical knowledge in practical aspects. It gave me first-hand experience of working as an engineering professional. It helped me in improving my technical, interpersonal and communication skills, both oral and written. Overall, it is a great experience to have software training in such a reputed firm and I believe that it will help me in building a successful career.

CONTENTS

- Introduction
- Benefits of AutoCAD
- AutoCAD Screen
- Methods to work in AutoCAD
- Drawing Units
- Dimension Style Manager
- Some Commands with Shortcut in AutoCAD
- Text Command
- Block Command
- Hatch Command
- Drawings made in AutoCAD
- Layout
- Drawing on Layout
- Conclusion

INTRODUCTION

- AutoCAD is the software majorly used for drafting purpose.
- The word AutoCAD is made up of two words "Auto" (digital) and "CAD" (Computer Aided Designing).
- It is developed by Autodesk Company.
- CAD is a utility tool or technology that is used for sharing of information with the help of computer.

BENEFITS OF AUTOCAD

- File Handling
- Global File Sharing
- Easy to Modify
- More Accurate and Precised
- Improved Quality Over Hand Drafting
- More Reliable

AUTOCAD SCREEN

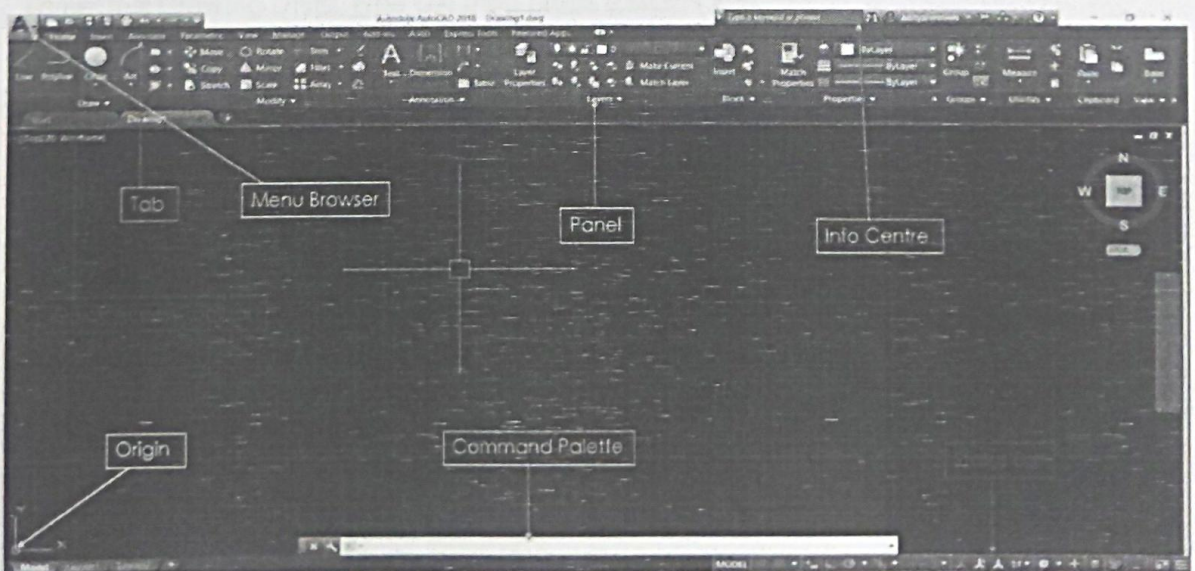

METHODS TO WORK IN AUTOCAD

+ GUI (Graphic User Interface):-



In this interface we can choose tools by selecting its graphical representation or icon to work in AutoCAD.

+ CUI (Command User Interface):-

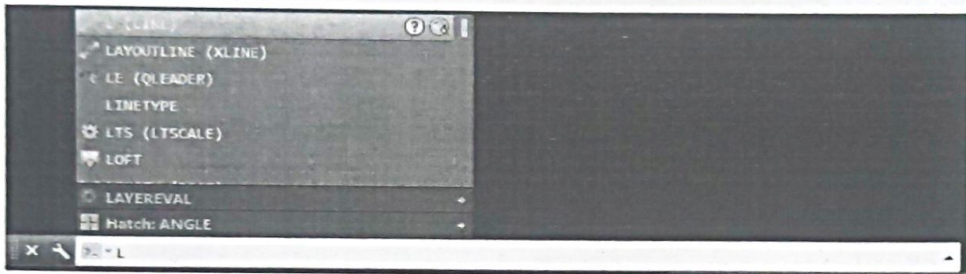

In this interface we can type the command in command palette to work in AutoCAD.

DRAWING UNITS

To set the Drawing Units, type **UN** then press **ENTER** key. Then a pop-up window will appear. Then do the changes as per requirements. Then click **OK**.

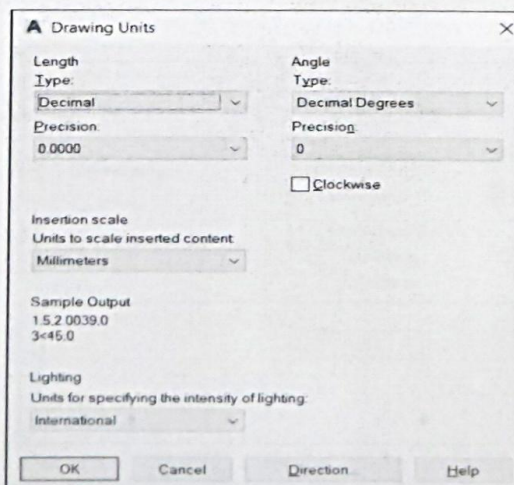

DIMENSIONSTYLEMANAGER

To set the Dimension Style, type **D** then press **ENTER** key.
Then a pop-up window will appear.
Then click on **Modify**.
Then do the changes as per requirements.

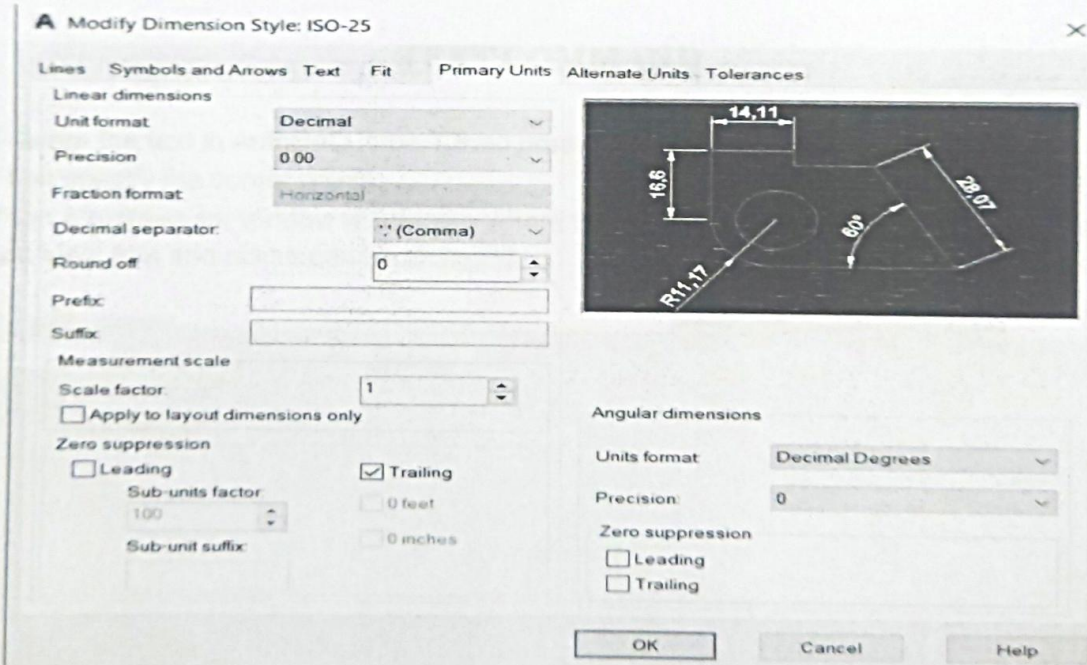

SOME COMMANDS WITH SHORTCUT

- | | | |
|----------------------|-----------------------------|--------------------------------------|
| 1) Line :- L | 24) Construction Line :- XL | 47) Dimension of Linear Line :- DLI |
| 2) Ortho :- F8 | 25) Array Classic :- ARRAYC | 48) Dimension of Aligned Line :- DAL |
| 3) Grid :- F7 | 26) Polygon :- POL | 49) Dimension of Radius :- DRA |
| 4) Osnap :- F3 | 27) Area :- AA | 50) Dimension of Diameter :- DDI |
| 5) Option :- OP | 28) Divide :- DIV | 51) Dimension of Angle :- DAN |
| 6) Offset :- O | 29) Point Style :- DDPTYPE | 52) Dimension of Arc Length :- DAR |
| 7) Trim :- TR | 30) Leader Line :- LE | 53) Dimension of Cont. Line :- DCO |
| 8) Mirror :- MI | 31) Special Line :- SPL | 54) Write Block :- W |
| 9) Pan :- PAN | 32) Stretch :- S | 55) Plot / Print :- PLOT / CTRL+P |
| 10) Copy :- CO | 33) Scale :- SC | 56) List :- LI |
| 11) Move :- M | 34) Hatch :- H | 57) Limit :- LIMIT |
| 12) Circle :- C | 35) Hatch Edit :- HEDIT | 58) Model View :- MV |
| 13) Rotate :- RO | 36) Block :- B | 59) External Reference :- XREF |
| 14) Ellipse :- EL | 37) Block Editor :- BE | 60) Chamfer :- CHA |
| 15) Rectangle :- REC | 38) Insert :- I | 61) Extrude :- EXT |
| 16) Polyline :- PL | 39) Design Centre :- DC | 62) Presspull :- PRESS |
| 17) Join :- J | 40) Table :- TB | 63) Union :- UNI |
| 18) Explode :- X | 41) Line Type :- LT | 64) Subtract :- SUB |
| 19) Extend :- EX | 42) Line Weight :- LW | 65) Loft :- LOFT |
| 20) Arc :- A | 43) Colour :- COL | 66) Revolve :- REV |
| 21) Fillet :- F | 44) Match Properties :- MA | 67) Sweep :- SWEEP |
| 22) Ray :- RAY | 45) Drafting Setting :- DS | 68) Slice :- SLICE |
| 23) Text :- T | 46) Line Type Scale :- LTS | |

TEXT COMMAND

To write the text in AutoCAD, type **T** then press **ENTER** key.

Then specify the corner points.

Then a rectangular window will appear where text can be typed. Also, from upper panel text size, font and colour can be changed.

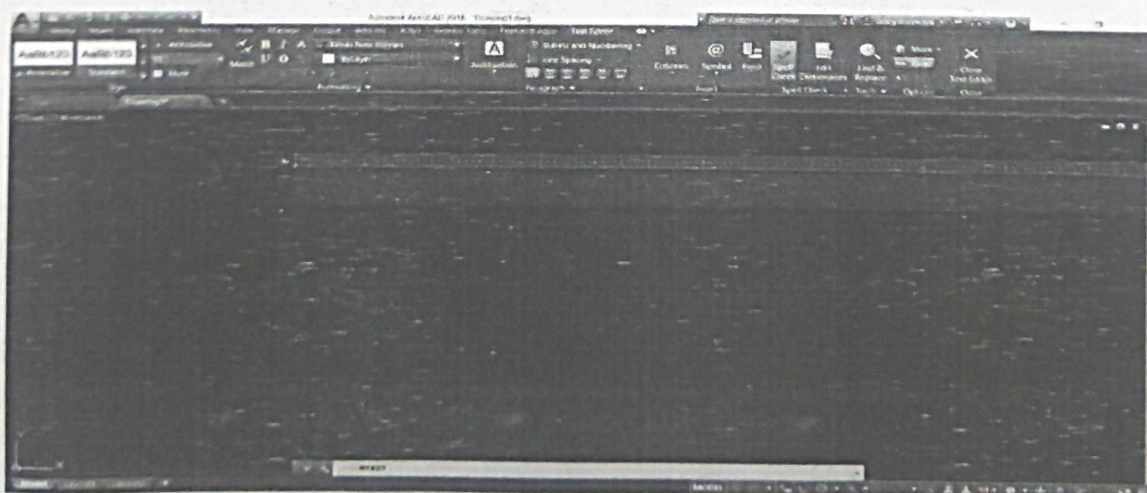

BLOCK COMMAND

When the same object shown multiple times in a diagram then we use block command. First, we draw that object then type **B** then press **ENTER key**. Then a pop-up window will appear where we first provide a name then select the object then specify pick point. Then click **OK**.

To insert the block, we first type **I** then press **ENTER key**. Then select the block by choosing its name. Then click **OK**. Then click on screen with left mouse button to put that object where it is required.

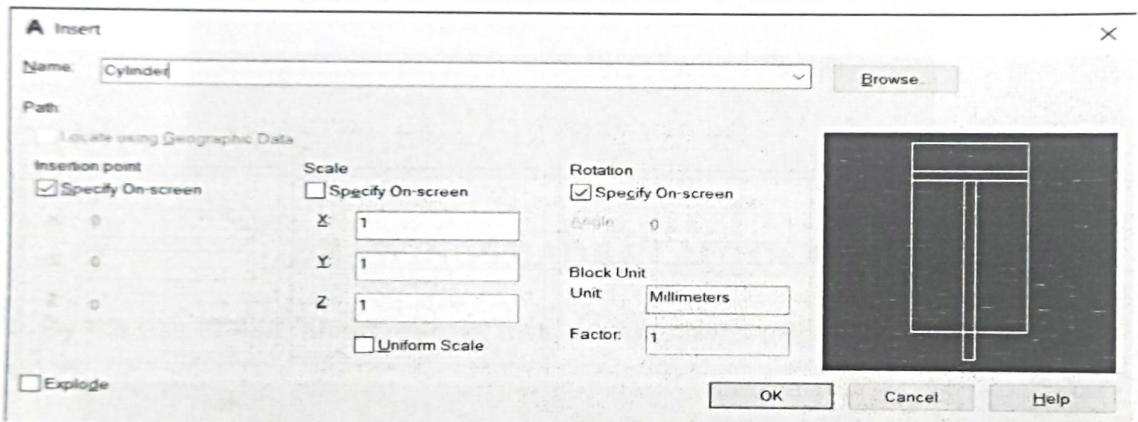
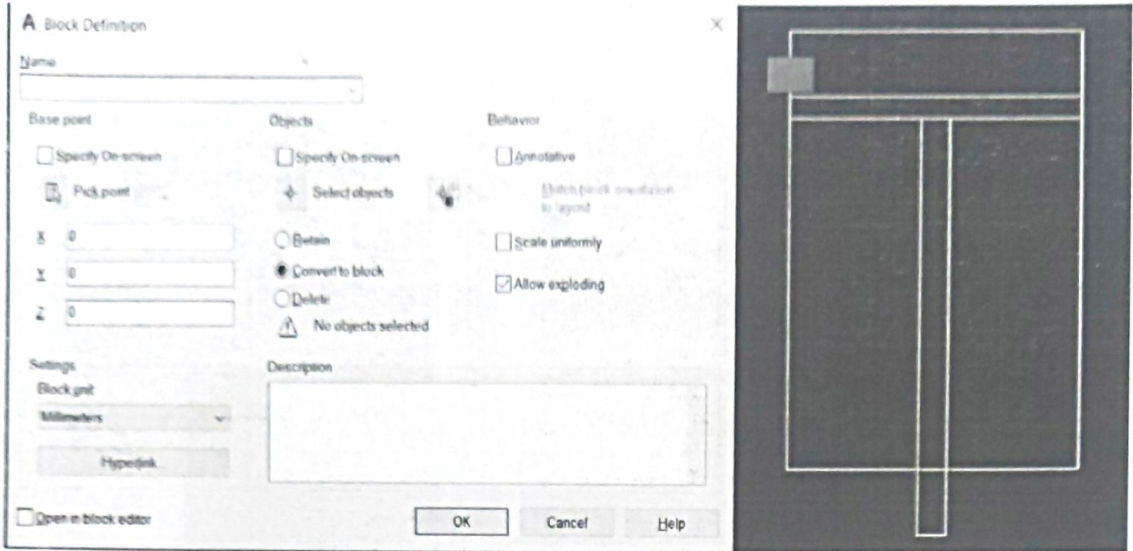

HATCH COMMAND

Hatching is used in technical drafting to communicate that an area of the drawing has a particular attribute. It indicates that a section cut through a part is a particular material or attribute.

For hatching, type **H** then press **ENTER key** then type **T** then press **ENTER key**. Then a pop-up window will appear on screen. Then we change pattern, colour, angle and scale according to the requirements. Then click **OK**.

If we have to edit the hatching, type **HEDIT** then press **ENTER** key and click on the hatched area and do the changes.

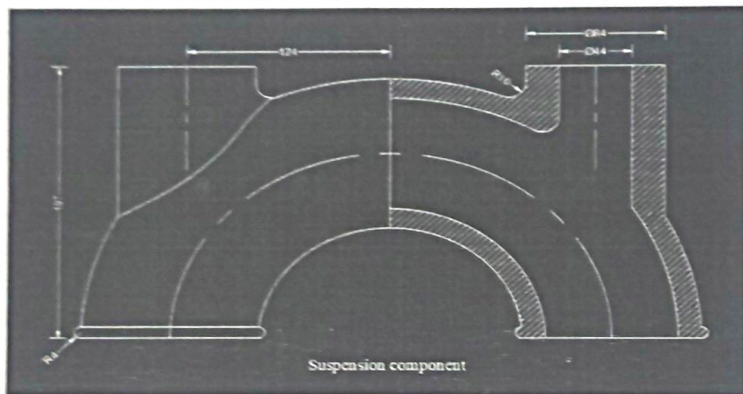

DRAWINGSMADE IN AUTOCAD

✦ By the use of line, offset, osnap, trim, mirror, circle, ellipse, arc commands.

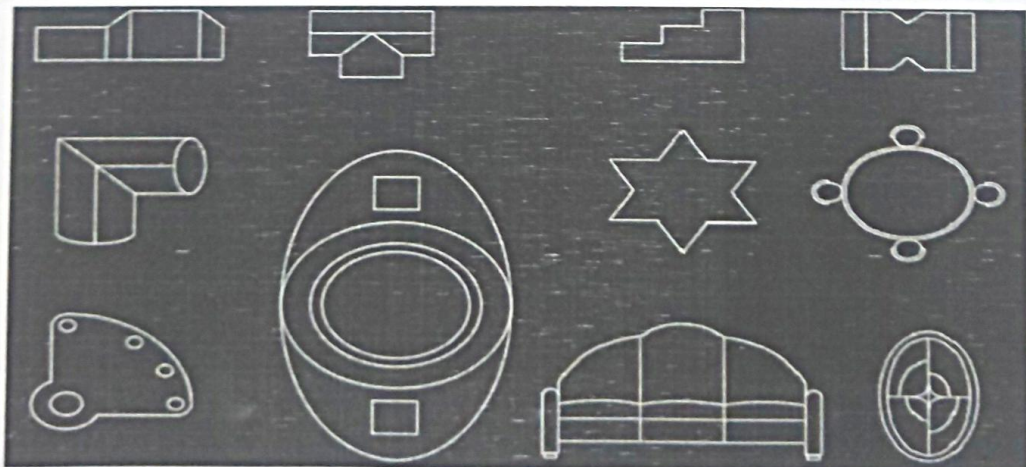

✦ By the use of line, offset, osnap, trim, mirror, circle, arrayclassic, ellipse, arc commands.

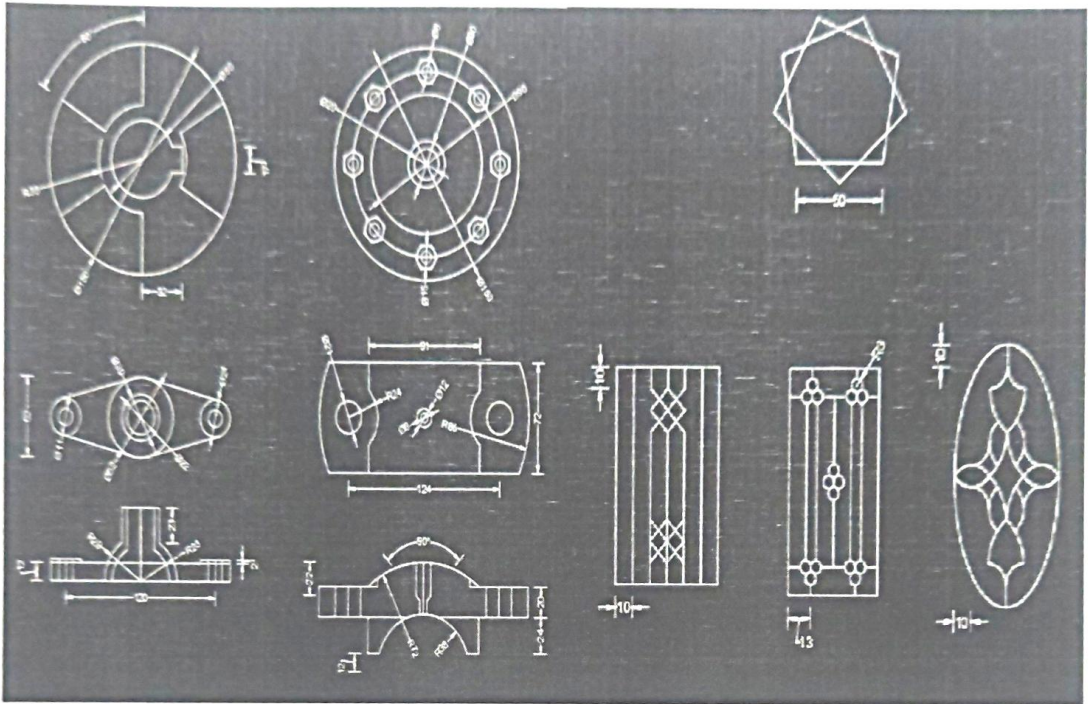

✦ By the use of line, offset, copy, osnap, trim, mirror, circle, special line, arrayclassic, ellipse, arc, construction line commands.

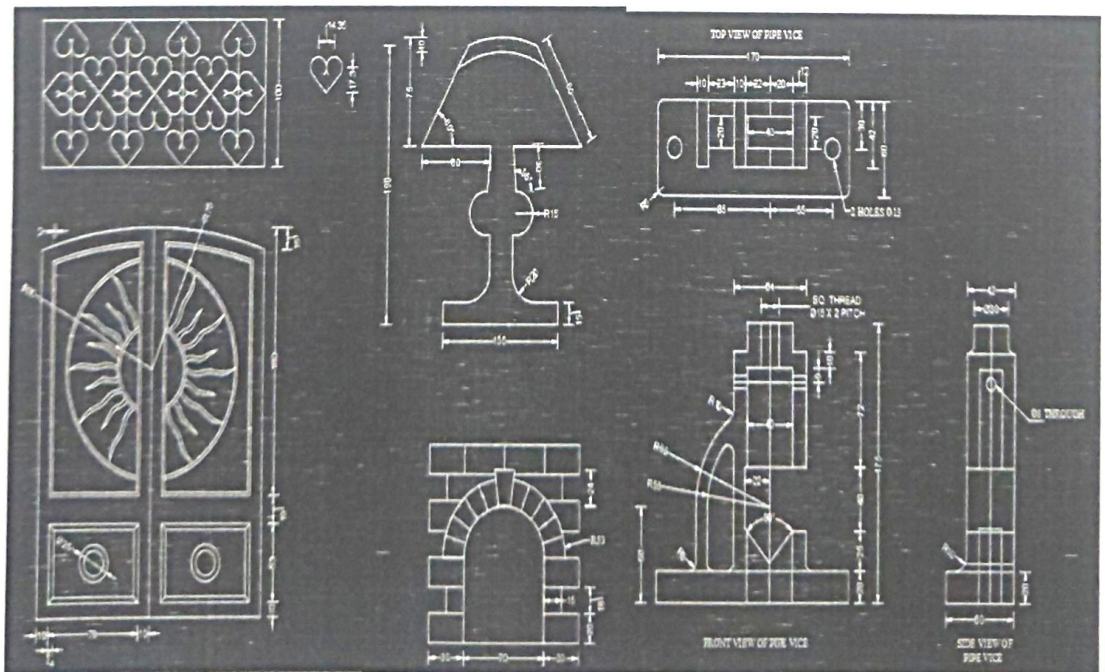

DRAWING ON LAYOUT

✦ In DWG form on layout

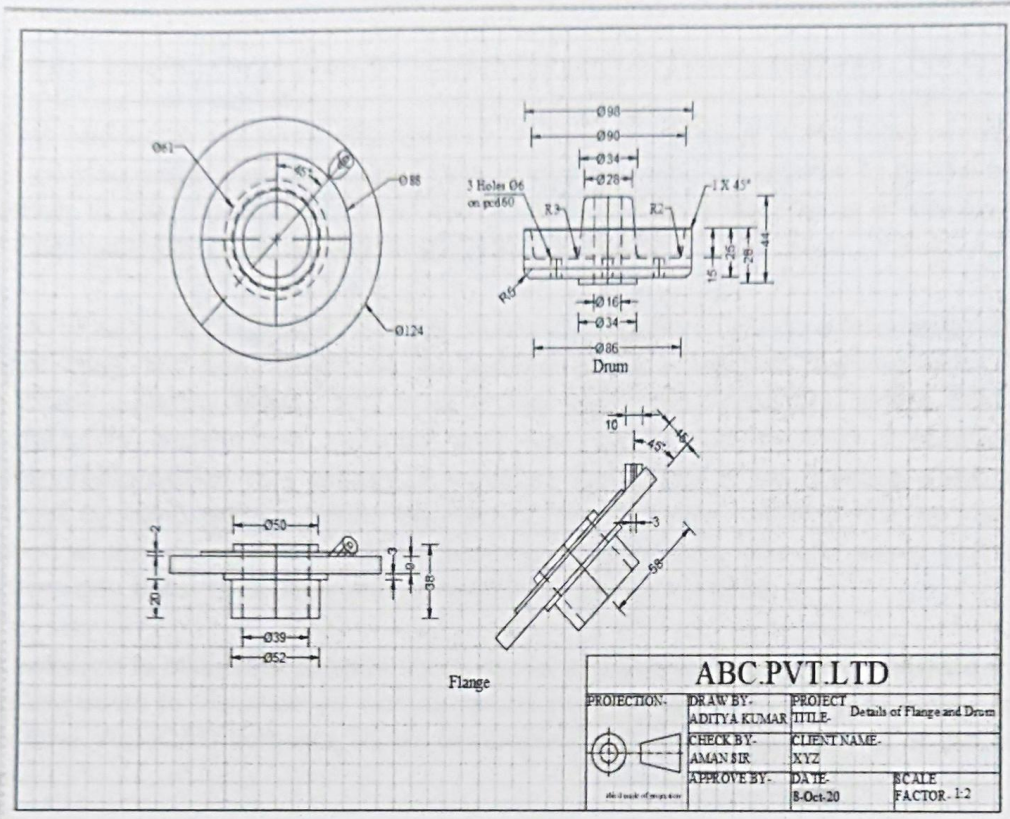

✦ In PDF form

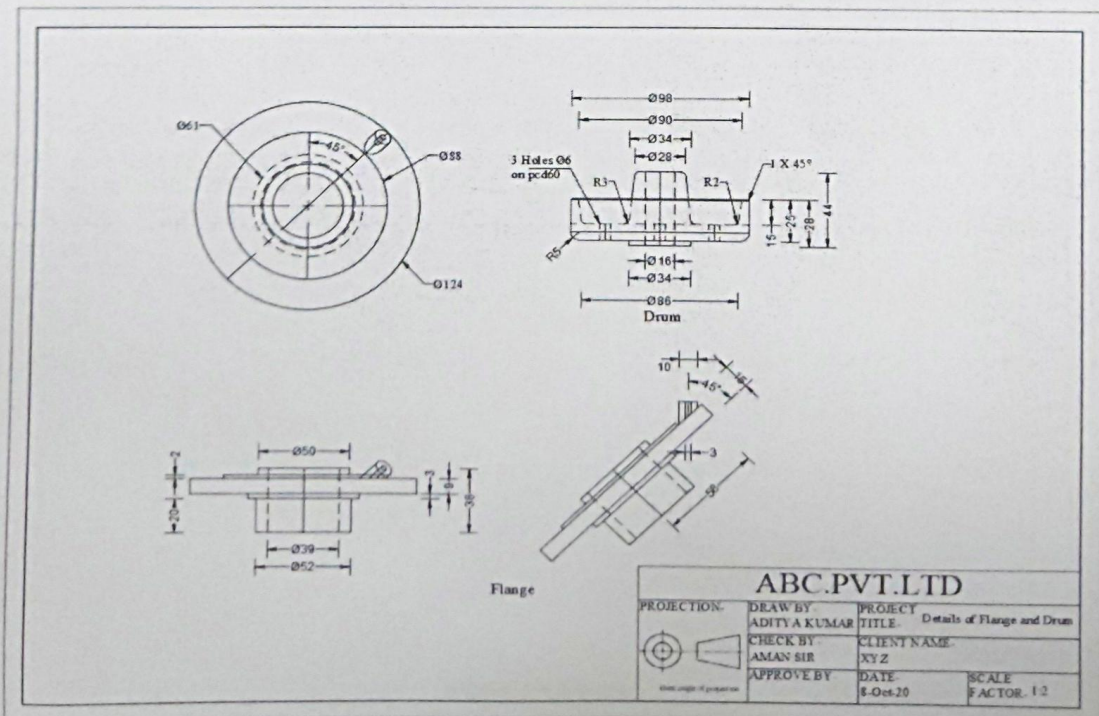

CONCLUSION

This report covered the preview of our learning path and study materials. The use of AutoCAD has many advantages. It can help to reduce the time it takes to produce the drawing needed in the work environment. AutoCAD software is the most amazing range of mechanical computer aided design tool. It is now considered to be the best according to industry standards that can be obtained for a wide array of designing, Civil Engineering Services and other industrial purposes.

The use of AutoCAD may also be relied on heavily in order to create efficiencies within the industries. We were guided by the fact that there is more to learning AutoCAD than drawing simple figures and lines. It has very vast application in the field of manufacturing, architecture, electrical, and many more. With the help of AutoCAD, we can create design very quickly. It improves the quality of the drawing which we can't get by hand drafting. With the help of this software, drawing can be easily modified whenever wanted which reduces the human effort. We can easily transfer files from one place to another in no time which reduces the time.

This software is utilized to provide some useful and practical designing software that will allow users to visualize as well as create prototypes of a product in reality and quick time. AutoCAD software allows developers to give form to their out of the box ideas.

LEARN DELTA

Certificate of Completion

THIS IS TO CERTIFY THAT

BALAJIT RAI

has successfully completed

AutoCAD-2D (FREE Online Workshop)

and scored an 'A' Grade in the prescribed final
examination conducted by Institute on **16/08/22-29/09/22**



Anjaneya Pali

DIRECTOR SIGN